



rights. riding. racing.

American**Motorcyclist** Association

2005

Pro-Am Speedway

Supplementary

Regulations

AMERICAN MOTORCYCLIST ASSOCIATION
13515 Yarmouth Drive
Pickerington, Ohio 43147
(614) 856-1900
(614) 856-1921 (fax)
www.AMADirectlink.com

Effective 2-15-05
Price \$3.00

TABLE OF CONTENTS

	Foreword	1
Chapter 1	Definitions	2
Chapter 2	Promoter Regulations	4
Chapter 3	Rider Licensing & Classification	8
Chapter 4	Entries & Fees	10
Chapter 5	Race Rules General	
	A. General	11
	B. Race Meets	12
	C. Race Programs & Goals	12
	D. Handicap Program	12
	E. Scratch Program	13
	F. Match Races	13
	G. 2 nd & 3 rd Division	13
	H. Youth	13
	I. Programs & Series	13
	J. Points	15
	K. Purse	15
	L. Race Rules.....	17
Chapter 6	Official Flags	25
Chapter 7	Apparel	26
Chapter 8	Technical Regulations	28
Chapter 9	Offenses, Penalties, Protests, Appeals and Hearings	35
Chapter 10	Officials Duties	46

FOREWORD

The American Motorcyclist Association takes pride in its long record of achievement as a governing body for the sport of motorcycling. In recognition of the need for controls over the sport, the American Motorcyclist Association has published competition rules since 1924.

THE RULES FOR COMPETITION ARE INTENDED ONLY AS A GUIDE FOR THE CONDUCT OF THE SPORT PURSUANT TO UNIFORM RULES. RULES DIRECTED OR RELATED TO SAFETY ARE PROMULGATED TO MAKE ALL PERSONS CONCERNED WITH SAFETY, BUT THE AMA NEITHER WARRANTS SAFETY IF THE RULES ARE FOLLOWED NOR COMPLIANCE WITH AND ENFORCEMENT OF RULES. MOREOVER EACH PARTICIPANT IN COMPETITION HAS THE RESPONSIBILITY TO ASSESS THE SAFETY ASPECTS OF FACILITIES AND CONDITIONS AND MUST ASSUME THE RISK OF COMPETITION.

Any communications regarding these Rules or regarding motorcycle competition as affected by these Rules should be made to the AMA at 13515 Yarmouth Drive, Pickerington, Ohio 43147.

Copyright© 2005 by the American Motorcyclist Association. Printed in USA.

No portion of these rules may be copied or used without the express written consent of the AMA.

CHAPTER 1 - DEFINITIONS

The following definitions and abbreviations are adopted for use in these rules.

1. AMA - American Motorcyclist Association.
2. Aftermarket - Manufacturer or fabricator other than the original equipment manufacturer.
3. cc - Cubic centimeters.
4. cu. in. - Cubic inches.
5. Entry Closing - A predetermined deadline for entry.
6. Displacement - The space covered or volume swept out by the piston at each stroke.
7. Disqualification - Unless otherwise defined, means the forfeiture of all awards, prizes, and points earned in all events during the day's meet.
8. Event - Any one of the races in a meet.
9. Handicap Race – A race in which riders start from the starting line or assigned distances behind the starting line, according to their skill levels.
10. Manufacturer - The original manufacturer of the motorcycle in question.
11. Meet - A race program in which one or more events are held.
12. Motorcycle - A single engine, single track, two wheeled, rear wheel drive vehicle to be identified by its frame number, frame tag or other frame marking.
13. OEM - Original equipment manufacturer.
14. Officials - See Chapter 10.
15. Paddock - Designated area for maintenance of competition motorcycles. May also include parking area for motorcycle transport and support vehicles.
16. Pit Crew - Mechanic and/or assistants.

17. Pits - Designated area directly adjacent to race track that may include staging and signal zones. Access is limited to mechanics or officials with appropriate credentials.
18. Program - The predetermined outline of events that make up a meet.
19. Promoter - Any person or persons, company, corporation or club holding, proposing to hold, or organizing a meet.
20. Race - Competition in which two or more riders compete against each other.
21. Race Track or Circuit - These will include the actual racing surface and run off areas, the pit road and grid, a test track when provided and any other area where the riding of competition motor-cycles is permitted.
22. Rider - Any person who competes in a meet.
23. Scratch Race – A race in which all the riders start from the starting line.
24. Suspension - (with respect to penalties). The loss of all rights to compete as a rider or member of a pit crew for the stated period.

CHAPTER 2 - PROMOTER REGULATIONS

A. Duties and responsibilities for all race meets.

1. Promoter will provide sufficient security measures and personnel to keep the track, pit and fences clear of spectators.
2. Promoter will provide the necessary equipment and personnel for track preparation and maintenance, including dust prevention.
3. **MEDICAL SERVICES**
Promoters are responsible for notifying local hospitals and trauma centers in advance of each meet's schedule. Promoters must also provide the following materials and services, which must be present and operational at all times machines are being ridden, and for 30 minutes after the final event of the meet:
 - a. At least one ambulance and driver capable of legal transport of injured persons, with an operating oxygen supply. In the event all ambulances leave the facility, on-track activities must be immediately suspended until at least one is back on station.
 - b. At least one qualified physician or certified trauma-trained paramedic. The cost of these services, and of track-to-hospital ambulance service for injured participants, is the responsibility of the promoter.
4. a. Promoter will provide a sufficient number of fire extinguishers, and personnel instructed in the use of these extinguishers in the pit area and on the course. Extinguishers must be fully charged and have a minimum rating as follows:
 - Pits: 4a 40bc rating
 - Track: 4a 40bc, or 10bc rating.
- b. A water source is required on the track and in the pit area to extinguish methanol fires.
5. Promoter will provide a paddock area with the following provisions:
 - a. This area will be separate and protected from spectator area by adequate fencing.
 - b. Access to the actual track.
 - c. Sufficient sanitary facilities. (Portable toilets accepted.)
 - d. Sufficient area to accommodate all racers and officials, including their vans and trailers; otherwise, separate rider vehicle parking areas must have adequate guards for security.

- e. Sufficient area to accommodate rider and mechanic when teardown is requested. Such area will provide good security and protection from the elements.
 - f. Designated area for vehicle impound.
6. Promoter will provide a sufficient number of flagmen.
 - a. Each flag station must be supplied with a minimum of one 24" x 24" yellow flag.
 - b. Flag men must be of sufficient size and strength to be able to remove a motorcycle from a fallen rider.
 7. If entry blanks are used by promoter or clubs, they will be subject to approval by the AMA.
 8. The promoter will be obligated to exhibit, on request, the official AMA sanction before a meet.
 9. **ADVERTISING**
 - a. A promoter must not make false announcements, advertising or otherwise distribute information to the press or public which is incorrect or misleading.
 - b. All printed advertising of sanctioned meets must include the AMA logo and the words "AMA SANCTIONED" or "SANCTIONED BY THE AMA".
 - c. Radio and television or any other form of audio advertising, must include the words "AMA SANCTIONED" or "SANCTIONED BY THE AMA".
 - d. A promoter is fully responsible for all advertising associated with the meet.
 10. The promoter will be responsible for the issuance of all press credentials, for the issuance of special instructions to these individuals and for providing adequate information services at the race.
 11. The promoter will have available at the conclusion of the meet, in cash, or as required, all prize money for either current race or previous week race.
 12. Promoter will provide a suitable scoring facility, which will include

good visibility, security, tables and chairs, protection from weather and sanitary facilities.

13. At the direction of the referee, obstacles must be removed or padded with straw bales or other suitable padding.
14. All spectator areas must be adequately fenced.
15. It is the sole responsibility of the promoter to insure compliance with all rules relating or directed to safety and to otherwise act to promote the safety of the meet. The AMA does not attend or in any way supervise meets and cannot undertake to determine safety aspects.
16. The promoter is responsible for securing participant and spectator legal liability insurance from the AMA's preferred carrier or another carrier approved by the AMA. Promoters are not required to provide rider medical insurance. Riders are reminded of the optional ARMOR insurance coverage available to all AMA members.

B. Application for sanctions

1. An AMA sanction must be obtained, and must not have been withdrawn or canceled, before any Speedway meets may be run by the promoter. A sanction can only be issued after proper application and approval by the AMA.
2. Sanction applications may be obtained from the AMA office and must be filled out in full.
3. This sanction covers standard AMA Pro Am races. If any other event is scheduled or contemplated for the same date, give details.
4. All applications for sanctions must be received at least 30 days in advance of the date set for the meet.
5. Applications for sanctions of Championship, Classic, or Special Meets or meets International in character must be submitted to the AMA for review and approval.

C. Rules Governing Sanctions

1. Sanctions are nontransferable and nonassignable without the permission of the AMA.
2. The AMA may refuse to grant a sanction, and may withdraw or cancel a sanction already granted for any reason which the AMA

deems to be in the best interest of the sport, or the participating riders, including the violation of any of these Rules for Competition.

3. Written approval of the AMA must be obtained for any meet which is to be cosponsored or cosanctioned.
4. In all cases, once the program of races is canceled due to rain or other circumstances, the travel cost of the Referee must be paid.
5. Sanction fees: Contact the AMA office in Pickerington, Ohio for fee structure.

CHAPTER 3- RIDER LICENSING AND CLASSIFICATION

Speedway is AMA Pro Am sanctioned.

1. Riders are required to have a valid AMA or ATVA competition membership card. To assist in identifying riders, sidecar drivers and passengers and mechanics, there is a special AMA application form available from registration clerks at each track.
2. Riders in FIM International Events and Championship Series require special licenses. Contact the AMA office for application form and costs.
3. Rider classification is at the option of the promoter. Normally riders are classified either:
 - 1st Division - any rider earning \$600.00 or more of basic Division 1 purse, in a single season, will be eligible for a two digit number if available.
 - 2nd Division - will consist of all intermediate riders. At promoter's discretion, second division riders may be moved temporarily to first division for a meet at that particular track only.
 - 3rd Division - beginning riders.
4. The minimum age to ride Division 1, 2 or 3 AMA Speedway is 16. Exceptions may be granted by the AMA in extraordinary circumstances. Riders under the age of 16 requesting classification as a Division 1, 2 or 3 rider must submit a written request to their promoter. If the requested classification is recommended by the promoter and track referee, the request should be submitted to AMA Sports along with letters of recommendation. Final determination rests with the AMA.
5. Youth Speedway
Youth Speedway classes are available for riders aged 4-15 as follows:
 - i. Class 1: 4-8 Years old -- 51cc maximum displacement, 2-stroke or 4-stroke engines. Riders may be classified at option of promoter as A, B, or C (beginner). Under no circumstances may Class 1 machines be allowed on the track at the same time as larger machines.
 - ii. Class 2: 7-11 years old -- 85cc maximum displacement for 4-

strokes. Riders may be classified at option of promoter as A, B or C (beginner). At option of promoter, 2-stroke and 4-stroke machines may be run separately.

- iii. Class 3: 10-15 years old -- 85cc maximum displacement for 2-strokes; 254cc maximum displacement for 4-strokes; allowance to 267cc is extended to air-cooled JAWA and Weslake engines introduced prior to 2004. Riders may be classified at option of promoter as A, B or C (beginner). At option of promoter, 2-stroke and 4-stroke machinery may be run separately.
- iv. Class 2 and Class 3 machines may be grouped together at the option of the promoter, provided riders compete only within their own classification, i.e. A, B or C.
- v. Promoters, referees, parents and guardians are reminded that not only engine size, but "machine fit" is important in Speedway competition. All are reminded of the referee's authority to prohibit the participation of any rider judged by the referee to be unqualified to safely negotiate the course.
- vi. See Chapter 8 for additional equipment regulations for AMA Youth Speedway.

AMA Youth National Championship. The AMA Youth National Championship will be a single-day event with a traditional 16-rider championship format. The event will be open to riders aged 7-15, invited by the promoter with the approval of the AMA.

CHAPTER 4 - ENTRIES AND FEES

1. An entry will consist of a rider and a qualified machine.
2. Promoters may charge reasonable entry fees and pit gate admission fees of riders, mechanics and others with access to the pit area. Promoters may limit the number of mechanics in the pit area, but must allow at least two per rider.
3. SPEEDWAY SIGN-UP
 - a. Any rider who is not registered within 30 minutes of the advertised start time of the meet may be allowed to compete at the discretion of the event Referee.
 - b. Any rider officially signed in at any particular race meeting who fails to present himself at the start, or refuses to start in any race which he is due to ride, may be penalized.

CHAPTER 5- RACE RULES

A. General

1. Every club, association, promoter, rider and all other persons participating or in anyway connected with any meet will be bound by these Rules for Competition. Any supplementary rules, regulations, or procedures established by the AMA for the purpose of implementing, interpreting and enforcing these Competition Rules will be deemed to be a part of the Rules.
2. No one, except riders officially entered, may ride or practice on any race course on the day of the meet. Unofficial trials on the day of the race meet are prohibited. Special exhibitions may be an exception.
3. Riders are expected to attend all riders meetings called by the Referee and are responsible for being aware of all information provided at the meeting.
4. A rider entering the pits must ride or push his motorcycle in the designated entrance and exit lanes.
5. No rider will, at any time, ride in such a manner as to endanger life or limb of other riders, officials or the public.
6. Except when being raced or tested in designated testing areas, all motorcycles must remain in the pit or paddock area. Riding of competition motorcycles, other than on the actual race track or in specifically designated areas such as a test track is forbidden. It is strongly recommended that there be no riding of competition motorcycles in the paddock area.
7. When a rider or mechanic is testing a machine (in designated test area only), he must wear a helmet and be dressed to offer some protection (pants, shirts, shoes).
8. When competing in foreign countries, members will obey and come under the jurisdiction of the competition rules of the FIM and the recognized foreign governing body.
9. Any form of outside assistance on the course is forbidden except when the assistance is given by the officials placed by the Referee for the purpose of safety.
10. No betting will be permitted at any meet or exhibition sanctioned by the AMA.

B. Speedway Race Meets

1. A race meet will be an entire racing program.
2. After the season opener, it is the obligation of each rider to sign up for the following week's race meet.
3. All riders will be considered "Independent Contractors" and as such will not be required to ride in any race meet unless signed up in advance to participate. The promoter is not required to use any specific riders in a race meet.
4. Limits on titles - A promoter may not hold or advertise any event or race as an AMA Championship or National event, or with any other title which may be deemed by the AMA, to be either national or international in character, without the written permission of the AMA.

C. Speedway Race Programs and Goals

The following suggestions and guidelines are provided as a guide to promoters for establishing efficient and entertaining race programs.

1. Division 1 program generally should include both handicap and scratch racing; Divisions 2 & 3 handicap racing only.
2. Design a race program to be run, start to finish, in approximately 2½ hours.
3. Handicap program should proceed the scratch program.
4. Whenever practicable, both handicap and scratch programs should afford all riders at least two starts.
5. Scratch program should include the 16 highest-ranked Division 1 riders present.
6. Scratch and handicap heats should be equal in strength as determined by riders' handicap ratings.

D. Handicap Program

1. All riders will be rated by yardage as determined by the promoter and referee, based on past performance.
2. Each rider's handicap will be established prior to the race meet and may vary from track to track.
3. A rider's handicap may be changed during a meeting, but only by

agreement of the promoter and referee.

- 4. Zero yardage riders will begin handicap events with their front wheel at the starting tapes. Other yardage lines will be marked in chalk on the racing surface.

E. Scratch Program

- 1. All-scratch programs may be held, but are generally reserved for championship and team events.
- 2. All riders, unless penalized, start from the tape line.
- 3. Starting positions for heat races are selected by ballot.

F. Match Races

- 1. These are special events featuring two riders, generally starting from the tape line.
- 2. Maximum laps: 4
- 3. A coin toss will be held for starting position, and the rider winning the toss will choose the inner or outer half of the track. The other rider must start from the other half of the track.

G. 2nd and/or 3rd Division Programs may be run

H. Youth Speedway

- 1. Youth Speedway programs for riders aged 4-15 are encouraged.
- 2. Youth Speedway will be guided by AMA Sports rules. The need for supplemental rules is recognized, and promoters and Youth Speedway Programs are authorized to develop such rules provided they do not conflict with these rules.
- 3. The rider must be large enough and mature enough to control his machine at all times and to ride it safely. This includes stopping, starting, standing still, mounting, dismounting and putting one or both feet on the ground. The referee has the authority to disqualify a rider that cannot safely control his/her motorcycle/minicycle.

I. Individual & Championship Programs & Series

- 1. The standard format for individual and championship programs is for 16 riders plus two reserve riders, but alternate formats may be used.
- 2. Rider positions will be selected by ballot by the promoter or by the

AMA for AMA National Championships.

- 3. Supplemental rules may be issued. For any AMA National Championships or international events, they are subject to AMA approval.
- 4. Championships may be earned from results in a single event or a series of events. Supplemental rules will be issued for any championship series.
- 5. Reserve riders will take the place of an absent rider or of riders who are present but unable to take part in a particular heat.
- 6. Reserve riders will alternate rides, with a maximum of five starts each.
- 7. Reserves may take the place of excluded riders in heat races only.
- 8. Reserve riders participate for prize money only and may not earn points or advance to an "earned race", i.e. Semi or final.
- 9. For a standard 16-rider format, 20 heats will be run with scoring on a 3-2-1-0 basis.
- 10. Riders must complete the race or be on the same lap as the leader when the checkered flag is displayed to receive points.
- 11. Results may be based on the points earned by each rider in the 20-heat program, or those points can be used to advance riders to semifinals and main events.

12. The standard 16-rider, 20-heat format is as follows:

Heat number	(Inside)		(Outside)	
	Red	Blue	White	Yellow
1	1	2	3	4
2	5	7	6	8
3	10	11	9	12
4	15	14	16	13
5	13	1	5	9
6	14	10	2	6
7	11	15	7	3
8	4	8	12	16
9	6	16	1	11
10	12	5	15	2
11	8	9	3	14
12	13	4	10	7

INTERVAL

13	7	12	14	1
14	2	13	8	11
15	16	3	10	5
16	9	6	4	15
17	1	8	15	10
18	9	2	7	16
19	3	12	13	6
20	5	14	11	4

J. Speedway Points

1. Points for the purpose of grading/ranking will be kept by the individual promoters. The following procedure for allocation of points may be used:
 - a. 1st Division: 5 points awarded for each program a rider competes in. 1 point awarded for each \$5.00 of purse earned. Example: #1 John Doe purse \$200.00 divided by 5 = 40 points + 5 points show up = 45 total points earned.
 - b. 2nd, 3rd Division and Sidecars: 2 points awarded for each program a rider competes in. 1 point awarded for each \$5.00 of purse earned or points by chart.

Handicap Heats	Handicap Semi	Handicap Consolation	Handicap Main
1-5	1-16	1-34	1-58
2-4	2-14	2-31	2-54
3-3	3-12	3-28	3-50
4-2	4-10	4-25	4-46
5-1	5-8	5-22	5-42
6-0	6-6	6-19	6-38

Scratch Heats	Scratch Semi	Scratch Consolation	Scratch Main
1-5	1-16	1-34	1-58
2-4	2-14	2-31	2-54
3-3	3-12	3-28	3-50
4-2	4-10	4-25	4-46
			5-42

K. Speedway Purse

The AMA sets regulations to cover purses. AMA Speedway event purse minimums:
 Standard Events: First Division, Handicap and Scratch \$1,375.00; Second Division \$110.00; Third Division \$80.00. Total Minimum purse \$1,565.00, or 24% of gross gate, whichever is greater. (back yardage not included).

Division I Back Yardage

40 yds - \$10.00
 50 yds - \$20.00
 60 yds - \$30.00
 Total Purse - \$1,565.00

Exceptions: Eastern US promotions and start-up promotions in areas where Speedway is not well developed may request special approval from AMA Sports to offer 2/3rds of the normal minimum weekly purses, i.e. \$1,043 against 24% of gross gate. When such approval is granted, the promoter must inform all riders accordingly.

Championship events minimums

Classics, Masters, Qualifiers, Track Championships, Team, Fair Derby and Championship format.
 1st Division Minimum of \$3,000.00.
 National Championships \$10,000.00
 State Championships \$5,000.00
 National Teams or Pairs \$3,500.00
 American Final \$5,000.00

Division I Handicap Payoff

Handicap Heats	Handicap Semi	Handicap Consolation	Handicap Main
1-\$10.00	1-\$15.00	1-\$25.00	1-\$130.00
2-\$ 5.00	2-\$10.00	2-\$20.00	2-\$ 85.00
3-\$ 5.00	3-\$ 5.00	3-\$15.00	3-\$ 60.00
4-\$ 5.00	4-\$ 5.00	4-\$10.00	4-\$ 50.00
5-\$ 0.00	5-\$ 5.00	5-\$ 5.00	5-\$ 40.00
6-\$ 0.00	6-\$ 5.00	6-\$ 5.00	6-\$ 30.00
<u>x 4 Heats</u>	<u>x 2 Semi</u>	<u>Consi Total</u>	<u>Main Total</u>
\$100.00	\$90.00	\$80.00	\$395.00
Handicap Total \$665.00			

Division 1 Scratch Payoff

Scratch Heats	Scratch Semi	Scratch Consolation	Scratch Main
1-\$15.00	1-\$15.00	1-\$30.00	1-\$170.00
2-\$10.00	2-\$10.00	2-\$20.00	2-\$120.00
3-\$ 5.00	3-\$ 5.00	3-\$15.00	3-\$ 80.00
4-\$ 5.00	4-\$ 5.00	4-\$10.00	4-\$ 55.00
<u>x 4 Heats</u>	<u>x 2 Semi</u>	<u>Consi Total</u>	<u>Main Total</u>
\$140.00	\$70.00	\$75.00	\$425.00
Scratch Total \$710.00			

Division II Pay Off

Handicap Heats	Handicap Consolation	Handicap Main
1-\$ 0.00	1-\$ 0.00	1-\$40.00

2-\$ 0.00	2-\$ 0.00	2-\$30.00
3-\$ 0.00	3-\$ 0.00	3-\$20.00
4-\$ 0.00	4-\$ 0.00	4-\$10.00
5-\$ 0.00	5-\$ 0.00	5-\$ 5.00
6-\$ 0.00	6-\$ 0.00	6-\$ 5.00
		Total \$110.00

Division III Pay Off

Handicap Heats	Handicap Consolation	Handicap Main
1-\$ 0.00	1-\$ 0.00	1-\$25.00
2-\$ 0.00	2-\$ 0.00	2-\$20.00
3-\$ 0.00	3-\$ 0.00	3-\$15.00
4-\$ 0.00	4-\$ 0.00	4-\$10.00
5-\$ 0.00	5-\$ 0.00	5-\$ 5.00
6-\$ 0.00	6-\$ 0.00	6-\$ 5.00
		Total \$ 80.00

TOTAL PURSE \$1,565.00

L. Speedway Race Rules

1. The starting gate will be set up supporting 2 or 3 tapes tightly stretched across the track and attached to the sliding portion of the starting gate. They must be directly above the starting line. The lowest tape will be 21" from the track surface. The tapes will be attached with rubber bands of a maximum length of 6" and a maximum width of 1". The tapes will not be so strong as to cause injury to a rider colliding with them.
2. Red and green lights will be placed in the riders' view at turn one and a red light at turn three, or flags to be controlled by the Referee.

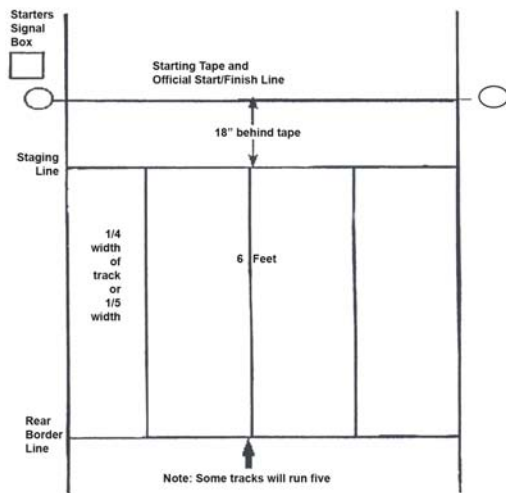

3. Starting boxes prior to each scratch event: 4 boxes evenly divided across the track with the tape/staging line as the front border, the start line 18" behind the tape line and the rear border line 6 feet behind the start line. (5 boxes at some tracks).
4. Back yardage lines prior to each Handicap Event: (in 10 yard increments as necessary, i.e., 10 yards, 20 yards, 30 yards, etc.) when marks are around curve of track they will be marked to equalize handicap distance.
5. No one is allowed to enter the race track without the permission of the Pit Steward or Referee.
6. No pit crews, mechanics or other unauthorized persons will be allowed in the infield at any time.
7. In the event of rain, or poor track conditions, the Referee and Promoter will determine a definite late starting time for the purpose of getting the track in satisfactory condition. Once a meet has started, the riders must be paid for all events run. If no spectator refunds are made, the promoter will pay the entire guaranteed purse.
8. The Referee may hear any case in which riders or pit personnel associated with the official program for that particular meeting have arrived at the meeting after the pit gate has been closed, but prior to the commencement of the official program. The decision as to whether the rider or pit personnel may take part in that particular meeting is at the discretion of the Referee.
9. Any change in the official programs, such as a consolidation of events, added events, or additions of riders will be previously approved by the Referee.
10. Consolidation of Heats
The designated official may, subject to the approval of the Referee, consolidate or otherwise modify the make-up of heats if the number of riders present at the start or other conditions warrant doing so.
11. The Referee, together with the promoter, may change a rider's handicap, ten yards at a time, up to twenty yards during a race meeting.
12. Start and Finish Points
The start and finish of a race or of an attempt at a record will occur when any part of the rider or his motorcycle passes over the starting line, always providing that the rider is in contact with the machine. The start and finish line are at the posts and tapes.

13. Outside Assistance

- a. A rider who receives outside assistance, in any manner whatsoever, will be excluded from the race.
- b. Any contact with the motorcycle or with the rider, whether in fact it assists the rider or not, may be deemed by the referee to be outside assistance.
- c. In the event of a rider falling or almost falling, and if he receives no outside assistance, he may continue to race, if the Referee does not exclude him as a safety measure. However, engines may not be restarted during a race.

14. Exclusion

A display of signals to indicate that the rider is excluded from a race will be given as early as is practicable after an offense has been committed. It will be the duty of the starting line official to display the spindled BLACK flag to the rider concerned. If a rider has made a legal start he will be entitled to start money.

15. Withdrawal from Course

Any rider whose exclusion from a race has been signaled by flag will immediately withdraw from the course. Failure to comply will incur further penalty.

16. Starts

a. Punctuality in Starting

- 1.) All meetings will be started at the published time.
- 2.) The Referee may, at his sole discretion, postpone the start of a meeting on account of weather conditions or other Force Majeure for a reasonable period.
- 3.) Riders will always be prepared to start in accordance with the program and when called upon to do so by the duly-authorized official.
- 4.) Any rider present at the meeting who is not prepared to start (that is, on the track proceeding under power in the direction of the course toward the start line) within two minutes after being called upon by the Referee will be excluded from the race and replaced by a reserve or tactical substitute. The expiration of two minutes will be determined by the Referee (May be one minute at some tracks.)

b. Procedures for Starts

All starts will be determined by the following method:

1.) Clutch Starts

- a.) On the instructions of the Pit Steward, the riders will leave the pits and proceed by the shortest practicable route until they reach the tapes where they will come to rest under the control of the Starting Marshall with their front wheels up to the tapes.
- b.) The Starter, once satisfied that the riders are correctly positioned and stationary, will switch on the green light after indicating to the Starting Marshall that the start is imminent and that he must leave the tapes.
- c.) After a pause sufficient to enable the riders to spin their engines and focus their attention upon the tapes, the Starter will release the gate.
- d.) Should the starting gate develop a fault which cannot be rectified, the Starter will start the race by switching off the Green Light.
- e.) The first rider who touches or breaks the tapes after the green light is on, will be excluded or penalized depending on the policy of the track/referee.
- f.) In all starts the Referee and/or Starter shall have the power to decide what is a fair start.

2.) Rolling starts, in handicap races

If a rider rolls on a start before the tapes go up, the race will be stopped and the rider penalized 20 yards back from his original starting position.

c. Exclusion in Starts

- 1.) A rider taking up the wrong position, not complying with the instructions of the Starting Marshall, or by any other means wrongly preventing the raising of the gate or the starting of a race, may be fined or excluded.
- 2.) If excluded, his place will be taken by a reserve if available.
- 3.) If through faulty action of the starting gate, or for some other reason, the Referee considers a fair start has not been given, he will immediately stop the race by giving the "stop" signal and order a fresh start, in which the riders will occupy their original starting positions.

- 4.) In first Division handicap, any rider who fails to start in or is excluded from a race that has been ordered to be re-run will be ineligible to take part in the re-run. A rider must complete the lap prior to the lap on which the race was stopped in order to take part in the re-run.

17. Foul or Dangerous Riding

- a. The Referee will exclude or penalize a rider who, in his opinion, engages in foul or dangerous riding.
- b. When, in the Referees opinion, such conduct has jeopardized the fair chance of one or more of the other riders, the Referee will stop the race and order a re-run.
- c. There will be no protest or appeal against the Referees decision as to foul or dangerous riding.
- d. Foul riding is defined as a rider purposely using any part of his body or his machine to physically make contact or interfere with another rider, including any rider who steers or drifts from his course in such a manner as to impede any rider who may be attempting to pass.
- e. Dangerous riding will be defined as a rider who, in the opinion of the Referee, is unintentionally riding in such a manner as to be hazardous to the other riders.

NOTE:Foul riding as described above may occur at more than one race track. No rider will commit three offenses during a 60 day period. On the fourth report of such violation, he will be excluded from all AMA sanctioned race meetings for the remainder of the season. Repeated violations during the season will be reviewed by the AMA.

18. The Referee will immediately exclude a rider, when both wheels of the rider's motorcycle have crossed the inner edge of the track, unless such action is taken in the interest of safety.

19. Procedures for Stops, Restarts and Re-runs

- a. Referee may exclude or penalize any rider he deems to be the primary cause of a race being stopped.
- b. The Referee may allow a reserve rider to take the place of a rider who is unable to restart in heat races only.
- c. Any rider eligible to take part in a re-run may change his

motorcycle for the re-run.

- d. The Referee will stop any race in which an accident has occurred, if in his opinion, it would be dangerous for the race to continue. A showing of the red flag will stop the race.
- e. The Referee may, by a showing of the red flag, stop any race in which one-half or more of the riders fall or do not complete the first lap, including a two man race. It will be the sole discretion of the meet referee to stop the race. Then he may or may not exclude the rider(s).
- f. The race will be red flagged if any rider, in the opinion of the Referee, has deliberately "laid down" his motorcycle to avoid a fallen rider. The rider who "laid down" his motorcycle will be allowed his position and the fallen rider will be excluded or penalized.
- g. The Referee will permit any rider who has fallen, either as a result of being fouled or because he deliberately "laid down" his motorcycle or has left the course in the interest of safety, to take part in the re-run of that event.
- h. A reserve rider may take an excluded rider's place in heat races only.
- i. Any rider, who in the opinion of the Referee, has deliberately "laid down" or stopped his motorcycle to force a restart will be excluded.
- j. If any race is stopped on the first lap, the riders will occupy their original starting positions including penalty yardage, if any. The referee may or may not elect to exclude a rider or riders from the rerun.
- k. The following rules apply to the handicap program:
 - 1.) Heats, semis, and the main will be restarted until the race gets to the final scheduled lap. Laps completed will count and will not be re-run. Riders guilty of offenses that cause a race to be stopped will be allowed to restart from the penalty line (ten yards behind the farthest line assigned to a rider in that event). After the first lap, riders will be lined up with adequate spacing, one starting on the zero yard line according to the position they held on the last completed lap, with the rider causing the restart (unless excluded) in back of the other riders.

- I. The following rules apply to the Scratch program:
 - 1.) In all heats and semis of regular non championship speedway programs, if one-half the number of required laps or more of a race have been completed before a red flag is shown, the race will be deemed complete, and the finishing order will be determined by the last complete lap. The referee will be the final judge of the finishing order. If fewer than 50% of the required laps have been completed before a red flag is shown, the race will be re-run. This rule does not apply to a two man race.
 - 2.) In all main events at regular non championship speedway programs and all heats of championship programs, races that are red flagged before the official race distance will be re-run. However, if the lead rider has begun the final lap when the red flag is displayed, the referee has the option of calling the race complete. The referee will be the final judge of the finishing order.
 - 3.) In National events, First Division Scratch riders must complete the same number of laps as the winner to be credited with a finishing position.
20. Every rider who qualifies for a semi-main event will be paid as scheduled regardless of whether he starts or not, unless his failure to start is willful or he is otherwise excluded.
21. If two riders are unable to start in an earned position, or if two are unable to finish a semi, consolation, or main and have not been disqualified by the Referee, each rider will be awarded one-half of the combined purse for the two finishing positions.
22. Once the Referee has declared the results of a race, these results may not be changed by way of a formal protest or appeal, although the Referee concerned may, of his own volition, make such corrections or amendments as he may think necessary, prior to leaving the speedway. In the event of a rider being excluded from a race which he has finished, the following rider or riders will be advanced one place accordingly.
23. No item will be thrown into the grandstands or any public area by a rider before, during or after a race meeting. This rule is intended to stop the practice of throwing gloves, helmets, goggles or foreign matter into the crowd and constituting a hazard to the public.
24. Special Medical Report
In order to satisfy themselves as to the fitness of a rider to participate in Speedway racing, the AMA may require him to be examined. If such medical report is deemed to be unsatisfactory, the AMA may withhold, withdraw or suspend the rider's membership.

CHAPTER 6 - OFFICIAL FLAGS

1. Green flag: Indicates start of race or clear track conditions.
2. Yellow flag: Indicates a potentially hazardous situation on or near the track. Exercise caution.
3. White flag: Indicates final lap of race.
4. Checkered flag: Indicates end of race or practice session. Proceed around course to the designated track exit.
5. Red flag: Indicates race has stopped and there is an emergency situation.
6. Black flag: Indicates a problem with your motorcycle or a disqualification. Riders are not permitted to return to the race course unless cleared by the Referee.

CHAPTER 7 – APPAREL

IT IS THE RESPONSIBILITY OF THE RIDER TO SELECT A HELMET AND APPAREL WHICH WILL PROVIDE APPROPRIATE PROTECTION. ALTHOUGH THE AMA ESTABLISHES EQUIPMENT MINIMUMS, THE AMA DOES NOT ENDORSE OR GUARANTEE SPECIFIC PRODUCTS OR MANUFACTURERS. RIDERS MUST RELY ON THEIR OWN JUDGMENT IN THE SELECTION OF HELMETS AND APPAREL FOR SAFETY AND DURABILITY.

A. Inspection

The Referee may disqualify any rider who does not conform to the Rules. Availability for inspection is the rider's responsibility.

B. Helmets

1. A full coverage or full face helmet is required.
2. A helmet must be worn during all competition. All helmets must be full coverage or full-face models. Helmets must be certified by the manufacturer and have a sticker affixed stating it meets or exceeds DOT, 90, 95 or any of the FIM approved certifications. The riders number may be placed on both sides of his helmet (using a contrasting color) to help scoring.

C. Eye Protection

Eye protection is required in the form of a face shield or goggles with shatter-resistant lens material.

D. Gloves

Gloves are required and must be made of leather or other comparable protective materials.

E. Footwear

1. Boots are required and must have a minimum height of 8".
2. A steel skid shoe must be worn on the rider's left boot. There should be no sharp edges.

F. Leathers or uniform

1. Protective pants made of leather or other durable materials are required.
2. Leather jackets or long sleeved jerseys and pads are required. Jerseys, if worn, must be tucked in.

3. The rider's name and number are required on the back of the rider's leathers or jersey.
 - a. The rider's name must be in block letters.
 - b. The rider's number must be clearly readable in letters at least 8" tall.

G. Pit attire and entry

1. All persons in the pits must be neatly dressed and wear shirts, shoes and pants. Open-toed shoes and sandals are not permitted.
2. Neat appearing team uniforms are encouraged.
3. The promoter may impose reasonable pit area attire and pit entry qualifications.
4. Riders permitting improperly attired and/or unqualified individuals to work in their pit area are subject to disciplinary action.
5. Riders are not allowed in the grandstand or other spectator areas while wearing their racing apparel.

CHAPTER 8 - TECHNICAL REGULATIONS

A. Motorcycle definition

A motorcycle is defined as a single engine, single track, two wheeled, rear wheel drive vehicle.

B. Motorcycle condition

1. The general appearance of the motorcycles must be neat and clean.
2. Construction must be workmanlike, with no exposed sharp edges.

C. Inspection

1. The AMA does not inspect vehicles in AMA Sports sanctioned competition. Participants are solely responsible for the condition of their vehicles and their competence to operate them.
2. Where the rules permit or require components to be installed, replaced, altered or fabricated, it is the sole responsibility of the rider to select components and materials and to perform fabrication so that the components will perform in competition with safety.
3. Technical inspections may be performed at the direction of the meet Referee. Availability for inspection at any time before, during or immediately after the meeting is the rider's responsibility.
4. The Referee may inspect any part or component of any motorcycle entered in competition at any AMA-sanctioned meet.
5. The Referee may disqualify any motorcycle that does not conform to the Technical Regulations, or disallow its use until it has been brought into conformity.
6. Compliance to the rules is required at any inspection, regardless of the motorcycle, equipment or riding apparel having passed prior inspections.

D. Equipment standards

1. Division 1, 2 and 3 Engines
 - a. Only air-cooled, single-cylinder, naturally aspirated & carbureted four-stroke engines may be used.
 - b. Maximum number of valves: 4.
 - c. Minimum displacement is 440cc.

- d. Maximum displacement is 511cc.
2. Youth Speedway Engines
- a. Only single cylinder, naturally aspirated 2-stroke or 4-stroke engines may be used.
 - b. Displacement limits
 - i. Class 1: 50cc Mini Class: 0-51cc
 - ii. Class 2: 66-85cc 2-strokes and 75-125cc 4-strokes.
 - iii. Class 3: 66-85cc 2-strokes and 75-254cc 4-strokes. An allowance to 267cc is extended to air-cooled JAWA and Weslake engines introduced prior to 2004.
3. Piston Displacement & Measurement
- a. Piston displacement is the space covered or volume swept out by the piston at each stroke.
 - b. Volume may be measured using the following formula:

$$V = BB(0.7854)HX$$
 - 1) V = Volume
 - 2) B = Cylinder bore
 - 3) H = Stroke
 - 4) X = Number of cylinders
 - c. If bore and stroke are measured in millimeters, divide the end product by 1,000 to convert to cubic centimeters.
 - d. If bore and stroke are measured in inches, multiply the end product by 16.387 to convert to cubic centimeters.
4. Carburetion and Fuel
- a. A single carburetor must be used, with a maximum throat diameter of 34mm, measured at 5mm before and 25mm after the closed throttle valve.
 - b. Fuel; Only neat (pure) methanol (CH₃OH) may be used. No additives are allowed.
5. Oil containment
- a. An effective oil-containment system which prevents any leaking of oil onto the ground is required.

- b. Riders are responsible for the proper disposal of oils and any other toxic or polluting liquids or materials.
 - c. No person may dump oil except in a suitable location designated by the promoter.
6. Frame; Speedway-type frames are required. No rear suspension is permitted.
7. Exhaust System
- a. All exhaust gases must pass through an exhaust pipe and an approved silencer, and must be discharged horizontally and to the rear of the motorcycle.
 - b. No part of the exhaust system may extend beyond the rear tire.
 - c. The exhaust pipe ("A") may not have an outside diameter of more than 50mm.

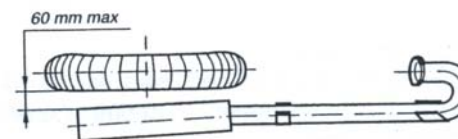
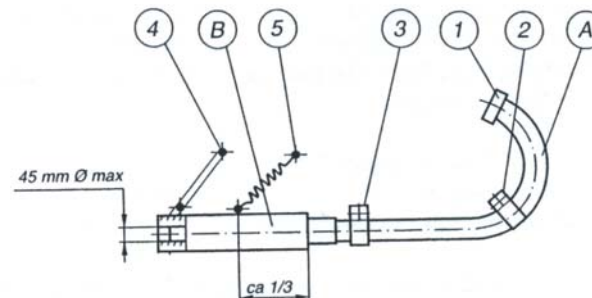

A = Exhaust Pipe (tuyau d'echappement)
B = Silencer (silencieux)

- d. The exhaust pipe will be secured at a minimum of three points: to the engine head at one point (#1) and the frame at two points (#2 and #3).

- e. The silencer will be secured at a minimum of two points: to the frame at one point (#4) and forward to the frame from within the front 1/3 of the muffler ("B") with a flexible steel cable or spring (#5).
 - f. The gap between the silencer and rear wheel may not exceed 2.5".
 - g. Silencers may not be modified to change the approved design.
 - h. Promoters will maintain and make available a list of approved Silencers at their respective facilities.
8. Transmission Guards
- a. The transmission must have a fully enclosed safety cover that protects against accidental contact with transmission or clutch parts. The following exceptions are allowed:
 - 1.) The vertical plane facing the motorcycle center may be open.
 - 2.) A hole is allowed on the vertical plane facing away from the motorcycle center, sufficient only to remove the clutch pressure plate and clutch plates.
 - 3.) 10mm or smaller holes are allowed, provided the number or placement of the holes do not compromise the integrity of the guard.
 - 4.) Sufficient clearance for rear chain entry and exit.
 - b. Additional protection from a broken primary chain flying upwards must be provided by the safety cover being constructed of steel, or by a bolt or rod of 10mm minimum diameter and of sufficient length, mounted parallel to the clutch shaft and placed adjacent to the clutch within 45 degrees rearward of the bottom of the clutch.
 - c. The final drive sprocket must be covered by a dedicated guard or by shared coverage from the primary transmission guard.
 - d. A rear sprocket/chain guard is required that covers all teeth on the sprocket that are not fully engaged with the chain, and that covers at least 3 inches of the chain as it meets the sprocket.
9. Brakes; Brakes are not allowed.

10. Wheels and Tires
- a. Wheel sizes must be 23" diameter (front) and 19" diameter (rear).
 - b. Tires will be of an approved model and brand. No material may be removed from tires and no new sipes may be added to tires, nor can tires be chemically treated.
 - c. Tires may not be modified.
 - d. Promoters may establish "edge rules" for weekly programs. No edge rules will be enforced for special events or AMA Championships.
11. Fenders and Wheel Covers
- a. Fenders are required over the front and rear wheels.
 - b. The front fender will commence no less than 5 degrees forward of a vertical line through the front axle and extend back at least 45 degrees from that line.
 - c. The rear fender will commence no less than 5 degrees behind a vertical line through the rear axle and extend forward at least 45 degrees from that line.
 - d. Fenders must cover the entire width of the tire, but may extend no more than 1" beyond either side of the tire.
 - e. A cover must be fitted to the right side of the rear wheel that covers the spokes from rim to hub.
12. a. Handlebars must be steel or aluminum.
- b. Handlebar ends must be plugged or rubber covered.
 - c. Cracked or broken handlebars are prohibited.
13. Control levers: Must have at least a 1/2" diameter round or ball end.
14. Throttle controls: Must be self-closing.
15. Ignition cutout system
- a. An automatic "deadman's" ignition cutout switch that is activated when the rider leaves the motorcycle is required.

- b. The switch must be located on the right half of the handlebar or handlebar mount and be operated by a non-elastic lanyard attached to the rider or his clothing at the right wrist.
- c. Maximum extended length of lanyard is 36".
- d. The lanyard "pull" to operate the switch must be a force of 10 lbs. or less.
- e. Neither the handlebars nor the front forks may be part of the switch's electrical circuit

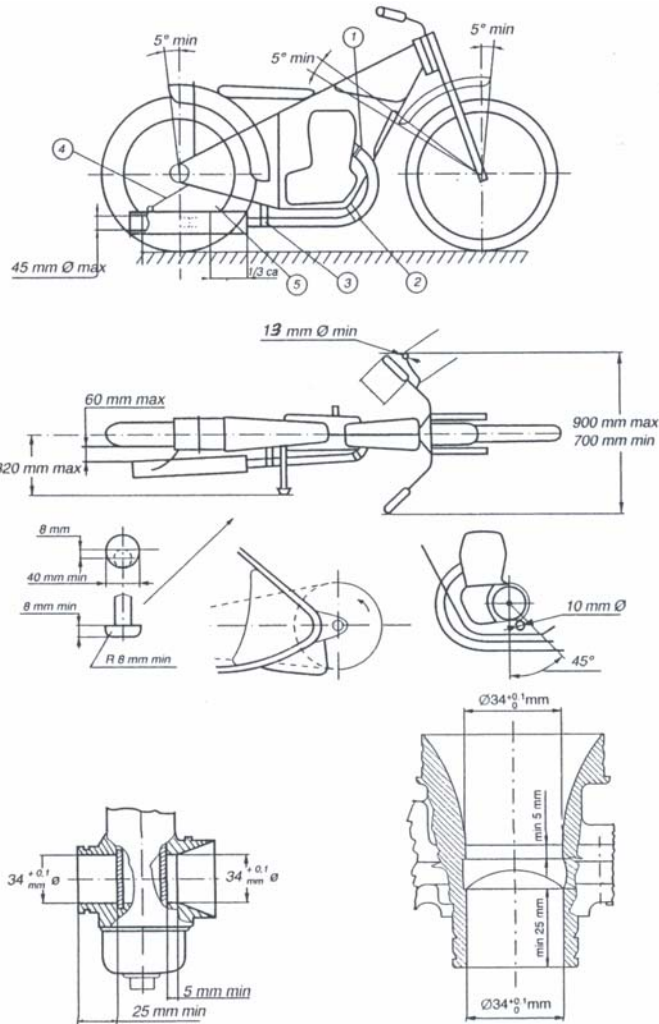

- 16. Footrests
 - a. a right side footrest is required and may not extend more than 12.5" from the centerline of the motorcycle.
 - b. The outer edge of the right footrest must be a minimum 40mm in diameter and 8mm thick with a minimum 8mm outer edge radius.
- 17. Number plate and numbers
 - a. A front number plate displaying the rider's number is required.
 - b. Numbers must be clearly visible, in a block style, done in a professional manner.
 - c. Numbers must be at least 6.0" tall and have a minimum 1" wide stroke.
 - d. Numbers must be of one color and the number plate of a contrasting color.

CHAPTER 9 - OFFENSES, PENALTIES, PROTESTS, APPEALS AND HEARINGS

A. General Information

1. Through the establishment and enforcement of various rules and procedures, AMA strives to regulate motorcycle competition in the fairest possible manner. By participating in an AMA meet, each participant agrees to abide by the AMA's rules and procedures. In addition, riders are deemed responsible for the actions of their families and crew members. All parties involved in AMA competition are expected to conduct themselves in a responsible manner, respecting at all times the rights of others. Participation in AMA sanctioned activities is a privilege, and all participants understand that violation of AMA rules and procedures can lead to forfeiture of their competition privileges.
2. Through its protest and appeal procedures, the AMA provides a system of administrative review in the event of disputes which are eligible for such review. The goal of the AMA's protest and appeal procedures is to assure fair and consistent enforcement of rules and objective review of protests and appeals lodged by or against participants.
3. Any participant who is fined under these rules will be deemed suspended from all AMA-sanctioned activities until the fine is paid. The fined party is entitled to a receipt upon payment. Fines and other disciplinary actions levied by meet officials or by AMA must be explained to the participant and noted in the referee report.
4. Any participant under suspension, or otherwise disciplined under these rules of competition, may be placed on probation or reinstated by the AMA.

B. General Offenses and Penalties

1. This section outlines actions which are deemed to be detrimental to the sport of motorcycle competition and which may result in a range of disciplinary actions.
2. Unless otherwise specifically provided for in these rules, the Referee may disqualify any rider, crew member or family member from a race meet for violation of these rules, insubordination or other actions deemed in the sole discretion of the Referee to be detrimental to the race meet and the sport. Such disqualification includes the loss of any rights with regard to the event in question and may result in expulsion from the meet site. In addition, the Referee is empowered to levy fines of up to \$100 and to

recommend to the AMA that further disciplinary actions be taken. The Referee may also disallow use of a motorcycle determined by the Referee to be illegal under these rules.

3. Unless otherwise specifically provided for in these rules, AMA is empowered to suspend any rider, crew member or family member for a period of from 15 days to indefinite suspension for violation of these rules, insubordination, or other actions deemed, in the sole discretion of the AMA, to be detrimental to the sport. The beginning and ending dates of any such suspension will be determined by the AMA. The minimum suspension for a second offense of a similar nature shall be six months. In addition, the AMA is empowered to levy fines of up to \$500.
4. Any supplemental rules, regulations, instructions or procedures established by the AMA for the purpose of implementing, interpreting or enforcing these rules will be deemed to be part of the rules.
5. The following offenses are subject to disciplinary action by the Referee and/or AMA. This list is provided as guidance to competitors but does not restrict the AMA from invoking penalties for other actions detrimental to the sport which are not specifically contemplated herein.
 - a. In any way attempting to gain an unfair advantage.
 - b. Falsifying one's name, age or ability level, or competing or attempting to compete under false pretenses. The penalty for riding in a lower classification than entitled (i.e. an "A" class rider competing in the "B" class) shall be a fine and a suspension of up to one year.
 - c. Failing to attend mandatory riders' meetings.
 - d. Riding in such a manner as to endanger the life or limb of others.
 - e. Failing to immediately respond to a black flag or other signals from officials.
 - f. After leaving the track during a competition, failing to re-enter at a point as close as practical to the point at which the rider left the track; and in so doing gaining an unfair advantage.
 - g. Receiving any form of prohibited outside assistance, including, but not limited to, receiving radio transmissions while in

competition.

- h. Causing a race to be stopped. At the Referee's discretion, a rider judged to have caused a red flag may be excluded from restarting the event.
- i. Abetting or knowingly engaging in a race in which the result is "fixed" or prearranged.
- j. Giving, offering or promising, directly or indirectly, any bribe in any form to any person in an attempt to circumvent AMA rules or procedures or to otherwise gain an unfair advantage.
- k. Accepting or offering to accept any bribe in any form from any person in an attempt to circumvent AMA rules or procedures or to otherwise gain an unfair advantage.
- l. Wagering on the outcome of any AMA-sanctioned competition.
- m. Knowingly entering or starting competition with a motorcycle that has been disqualified or is ineligible for the class entered.
- n. Changing the specifications of a motorcycle that has already been admitted for competition and/or inspected.
- o. Refusing to submit a machine or component (including fuel) for inspection, measurement or testing. Such refusal will result in the forfeiture of all points, prizes and rights at the race meet in question, plus a fine and one-year suspension.
- p. Failing to comply with various AMA "claiming rules."
- q. Refusing to provide a factual statement regarding an item under appeal when requested by the AMA or a party to the appeal; or interfering in any way with the AMA's protest and appeal procedures in order to hinder the process or influence the outcome.
- r. Attacking an AMA or meet official or engaging in a fight. This includes any person and any incident anywhere on the premises prior to, during, or after an AMA sanctioned meet. The penalty for such violations shall be a fine of up to \$500 and an indefinite suspension pending review by the AMA.
- s. Engaging in any unfair practice, misbehavior or action deemed

by the Referee or AMA to be detrimental to the sport.

- t. Conspiring with others to violate any of these rules.

C. Equipment Offenses and Penalties

1. This section deals with violations of equipment regulations. Regardless of a motorcycle passing prior inspections, compliance with all applicable equipment rules must be made at all inspections.
2. Any motorcycle found to be in violation of equipment rules may be assumed to have been in violation for the entire race meet. In permitting a motorcycle to practice and/or compete, race officials do not warrant that motorcycle's adherence with the AMA rules. Riders are responsible for any violation of equipment rules involving their motorcycle.
3. Under the direction of the meet Referee, motorcycles or components may be impounded following an event to allow for detailed or independent inspection and testing directed by the AMA.
4. Penalties
 - a. On the day of an event, and at the discretion of the meet Referee, any or all of the following penalties may be administered:
 - 1.) Disqualification
 - 2.) Total or partial loss of points and awards/prize money from the meet
 - 3.) Fine of up to \$100
 - 4.) Recommendation of further action by the AMA
 - b. Based on review of an event and/or recommendations of the Referee, the following penalties may be administered by the AMA:
 - 1.) Disqualification
 - 2.) Fine of up to \$500
 - 3.) Probation
 - 4.) Suspension

D. Protests

1. There are three types of protests:
 - a. Visual protests relate to motorcycles and components where compliance or noncompliance can be confirmed visually.
 - b. Technical protests relate to motorcycles and components where some type of measuring device or teardown procedure is needed to confirm compliance or noncompliance with the rules.
 - c. All other protests will be defined as administrative.
2. Unless specifically excluded herein, riders may lodge protests on any matter regarding an event in which they were a participant. Such matters may include, but are not limited to, the conformity of a machine or the eligibility of a rider.
3. Each protest must be made separately and in writing, signed by the protesting rider. Each protest must specify the violation of AMA rules or procedures which is alleged, and must be accompanied by the appropriate filing fee.
 - a. For each protest, \$25 per item or component protested.
 - b. In addition to the protest fee(s), a \$200 teardown fee will apply for a technical protest requiring measurement or teardown of an engine.
 - c. For a technical protest requiring the collection and test of a fuel sample, a \$25 protest fee plus a deposit of \$50 must be paid.
4. The Referee must accept any protest that is properly made within the specified time limit and accompanied by the appropriate fee. The Referee may not accept any protest that is not properly filed and accompanied by the required fee.
5. All protests must be filed within 30 minutes of the posting of results of the event in question.
6. Final determination of the timeliness of a protest will rest with the meet Referee and such decision will be final to all concerned.
7. The Referee will render decisions on all protests as soon as possible. If it is not possible to render an immediate decision, the Referee may allow a protested rider or machine to compete "under protest". In such cases, payment of all affected points and moneys will be withheld pending a decision on the protest.

8. When a protest involves piston displacement or any other internal engine modification, the Referee must call for an engine measurement or inspection after the meet. The protesting party must be present during the inspection, is entitled to witness the teardown, and must be informed of all measurements.
9. The Referee is empowered to levy appropriate penalties shown herein as the result of a protest and subsequent investigation.
10. Once made, a protest cannot be withdrawn without the permission of the Referee.
11. Any legitimate expense to which the Referee may be put as the result of a protest must be paid by the protesting party, and the Referee may require a deposit from the protesting party sufficient to cover such expenses. If the protest is upheld, however, such costs must be reimbursed by the protested party.
12. If a protest is decided in favor of the protesting party, the Referee will refund the protest fee and teardown fee, if any, and forward a report in writing to the AMA.
13. If a protest is decided in favor of the protested party:
 - a. In a protest not involving teardown fees, the Referee will forward the protest fee to the AMA along with a written report.
 - b. In a protest involving teardown fees, the Referee will forward the protest fee to the AMA along with a written report and the protested party will be entitled to the teardown fees.
14. The Referee may call for the inspection of any machine or component, including fuel, at anytime.
15. When a protest involves fuel, the losing party must pay all laboratory costs for fuel analysis. If the protest is upheld, the protester is refunded all fees and the protested party must reimburse the AMA for all laboratory costs.

E. Appeals

1. The AMA's process of administrative review provides two levels of appeals:
 - a. First Appeals: Items which may be appealed include the decision of a Referee on a protest and the imposition of penalties by a Referee and/or the AMA.

- b. Final Appeals: Appeals against the results of a First Appeal.
2. Items which may not be appealed include:
 - a. Protestable items for which no protest was lodged.
 - b. In general, appeals cannot be accepted related to matters for which no remedy is available. (For instance, no appeal will be heard if the only means of remedy would be to re-run an event.)
 3. All appeals must be in writing, accompanied by the appropriate fee and signed by the appellant. The appeal must specifically state the date and location of the sanctioned meet, the elements of the matter being appealed and the grounds for the appeal. The appeal may be filed with the Referee at the meet or submitted to:

AMA Director of Sports
13515 Yarmouth Dr
Pickerington, OH 43147
Fax: (614) 856-1921

Accepted delivery methods are facsimile transmission, United States mail or an express delivery service of the appellant's choice.
 4. The appellant is solely responsible for timely delivery of the appeal, appeal fees and related documentation to the AMA.
 5. Appeals must be received by the AMA before the close of business (5:00 p.m. Eastern time) on the fifth business day (Monday through Friday) after the ruling or incident under appeal.
 6. A filing fee of \$50 (\$100 for National events) must accompany a First Appeal. A filing fee of \$100 (\$200 for National events) must accompany a Final Appeal. Filing fees will be refunded only if the appealing party prevails. Laboratory fees for fuel testing must be paid by the appealing party and will be refunded only if the appealing party prevails.
 7. Both AMA and the appealing party are responsible for producing the following within 30 working days of the decision/incident being appealed (5 working days for a Final Appeal), and the AMA is responsible for distributing all such information to the appellant in a timely manner:
 - a. Copies of all written statements which will be offered as evidence at an appeal hearing.
 - b. A list of all witnesses to testify during the appeal hearing.

- c. In the case of a Final Appeal, any new evidence to be considered.
8. As soon as practical, AMA will review all materials submitted and take one of three initial actions:
 - a. Rule in favor of the appealing party, take appropriate remedial action and refund the filing fee;
 - b. If the matter appealed is a dispute between two parties, mediate the matter in an effort to reach an agreement between the parties; but failing to do so, convene an appeal board. (For these purposes, a "dispute" exists only if one party has filed a formal protest against the other. Having material interest in an appeal, e.g. being in a position to gain or lose money or points as a result of the outcome, does not constitute a dispute.)
 - c. Convene an appeal board.
 9. The time and place of hearings will be set by AMA. The appeal hearing will be convened as soon as practical, and barring unforeseen delays will be held no more than 45 days after the ruling/incident being appealed (for Final Appeals, 15 days after the decision of the First Appeal Board).

F. Appeal Hearings

1. First and Final Appeal Board hearings may be conducted in person or via telephone conference.
2. Each Appeal Board will consist of three persons with no material interest in the matter. Selection of the Appeal Board members is at the discretion of AMA, which will make every effort to assure a fair and impartial hearing.
3. The AMA Director of Sports or designee will serve as non-voting chairman of appeal hearings.
 - a. First Appeal Boards will include two members of the Off-Road Division of AMA Congress, plus one member of the AMA staff or another qualified party selected by AMA.
 - b. Final Appeal Boards will include three members of the Off-Road Division of AMA Congress.
 - c. In no case will the same person sit on both a First and Final Appeal Board considering the same situation.
 - d. If it is impractical to constitute a First or Final Appeal Board as

outlined above, alternate appeal board members may be appointed subject to the approval of the Chairman of AMA Congress.

4. No evidence or other information will be given to the Appeal Board members in advance of the hearing, and AMA will not announce the composition of the Appeal Board in advance of the hearing. Any effort by any party to unfairly influence a member of an Appeal Board may result in disciplinary action. For these purposes, any effort to discuss the matter under appeal prior to the hearing will be considered an attempt at influencing the Appeal Board member. It is the responsibility of all Appeal Board members to immediately report any such attempt at “tampering” to AMA.
5. AMA will confirm the time and place of all hearings in writing to the appealing rider and to the parties to any original protest. Such notice is to be made at least 10 days before the hearing (5 days for the Final Appeals) unless the appealing party agrees to shorter notice. Formal written notice will be deemed to have been given when mailed to the appealing party at the most recent address provided to the AMA. The AMA will make every effort to verbally confirm the time and place of the hearing.
6. Availability for the hearing will be the responsibility of the involved parties. If the appealing party fails to participate, the appeal board may go forward with the hearing. In the event of a documentable emergency on the part of the appealing rider, the hearing may be delayed at the discretion of the AMA.
7. The appeal hearing will be informal and formal rules of evidence will not apply. The following guidelines for conduct will, however, be enforced:
 - a. The chairman and members of the Appeal Board may at any time ask any questions they deem appropriate.
 - b. All parties involved in the appeal will be expected to provide full cooperation to the members of the Appeal Board in establishing pertinent facts and gathering information.
 - c. All comments from parties involved in a dispute will be to the Appeal Board members. No debate between disputing parties will be allowed.
 - d. The appeal hearing will be a closed meeting with attendance restricted to the following: The chairman, the members of the Appeal Board, the party or parties directly involved in the appeal

and their witnesses. Subject to the approval of the chairman, nonparticipating observers may also be admitted.

- e. Any party to a matter under appeal may request a written statement from any AMA official or member believed to have relevant information. Refusal by any AMA official or member to provide a statement or testimony when requested may result in disciplinary action as provided for in these rules.
 - f. Any party who fails to comply with these guidelines for conduct will be asked to leave the meeting and may be subject to disciplinary action.
8. The following order of business will be followed at appeal hearings:
 - a. Introductions and summary of matter under appeal.
 - b. Presentation of written and oral testimony, with the party in a “defense” posture presenting its evidence last.
 - c. Questions from the chairman and Appeal Board members.
 - d. Closing statements, again with the party in a defensive posture going last.
 - e. After all evidence has been presented, the Appeal Board will go into executive session to consider its decision. The chairman may, upon the request of at least two members of the Appeal Board, be present as a consultant to this process. During its executive session, the Appeal Board may, upon the request of at least two of its members, recall parties or witnesses for follow-up questions.
 - f. It is the responsibility of the Appeal Board to rule on the matter at hand within the context of existing AMA rules and regulations. Appeal Boards are encouraged to make recommendations regarding such rules and regulations but have no power whatsoever to waive or modify AMA rules.
 - g. Decisions of the Appeal Board will be by simple majority.
 - h. Upon reaching a decision, the Appeal Board will inform the chairman, who will assist in drafting the Board’s formal statement.
 - i. Upon completion of the Appeal Board’s formal statement, the appeal hearing will be reconvened and the chairman will read the statement.

j. The hearing will be adjourned.

9. If the Appeal Board members do not feel they can make a decision based on the evidence available at the appeal hearing, they will have up to seven days to conduct further investigations and reach their decision. If no decision has been reached within seven days of the appeal hearing, the Appeal Board will be dismissed. At that point, the AMA must either mediate a resolution to the appeal or convene a new Appeal Board.
10. The AMA will reimburse actual expenses incurred by members of the Appeal Board. Parties and witnesses will not be entitled to any such reimbursement.
11. If an appeal is upheld, the appealing party will be refunded their filing fee(s). If an appeal is denied, the fees will be retained by the AMA to defray costs.
12. While appealing a suspension, a rider may continue to compete in AMA events. However, this privilege may be denied at the sole discretion of AMA if the suspension is related to an offense involving drugs or alcohol, for riding in such a manner as to endanger the life or limb of others or for fighting.
13. The participants to a First Appeal agree that the determination of the Appeal Board is appealable only to an AMA Final Appeal Board. The participants to a Final Appeal agree that the determination of the Appeal Board is final, binding, and not appealable to the AMA or any court. The participants to any protest or appeal further agree that the protest and appeal procedures provided herein by the AMA are the exclusive method for the resolution of any disputes and renounce the right to pursue recourse to any arbitrator, court or other tribunal not provided for in these rules. Any attempt to do so may result in disciplinary action being imposed by the AMA. Said disciplinary action may include the permanent suspension of the appellant's AMA membership and all privileges related to that membership, including but not limited to the privilege of participating in AMA sanctioned competition.
14. Publication of protests, appeals, and the interim and final results of said protests and appeals in news releases, in American Motorcyclist magazine and other publications, on the Internet and through any other media is expressly agreed to by the participants to any protest or appeal. The participants further agree that they shall not bring a cause of action against AMA, its directors, officers, employees, Congress Delegates, agents and assigns as a result of such publication.

CHAPTER 10 - OFFICIALS DUTIES

A. Referee

1. The Referees of all meets will be appointed by the promoter and approved by the AMA.
2. Duties of the Referee will include the following:
 - a. Request the official sanction from promoter and keep the sanction until the meet is over.
 - b. To determine that qualified personnel are assigned to those positions necessary to ensure the efficient conduct of the event, and to provide payment for services rendered by officials in accordance with AMA guidelines.
 - c. Satisfy himself that the course is safe for the meet at the time of the meet and recommend to the promoter that the meet be called off at anytime the conditions make it unacceptable.
 - d. Determine if all riders are qualified to properly negotiate the course and prohibit any riders not so qualified from competing.
 - e. Provide for technical inspection of equipment being used by the riders and bar any equipment which does not conform to equipment regulations.
 - f. Direct or oversee the activities of all other track and pit officials.
 - g. See that accurate time is kept for all races (when required).
 - h. Obtain from the promoter the prize money, in cash, at the conclusion of the meet (or his designee). (Unless promoter operates a weekly show. Riders sign up for next weeks race and receive last weeks pay.)
 - i. Receive all protests and render decisions thereon, subject to appeal to the AMA.
 - j. Render all decisions on disqualification of riders, and disqualify any rider who violates any of the rules of the meet or the AMA.
 - k. Make a full written report within three days of all details of the meet, to the AMA.
 - l. The AMA and/or the Referee are empowered to measure engines.

- m. Allocate a properly enclosed location for engine inspection and measurement. Have engines ready for measurements on completion of meet.
- n. The Referee is empowered to make and enforce temporary regulations necessary to cover emergencies or special conditions (not covered in the Rule Book), including any unforeseen situation for the betterment and in the interest of the program. The Referee must consider all protests and immediately forward any appeals to the AMA.
- o. The Referee will be responsible for the collection of all Referee and Officials' fees and expenses, in cash, at the conclusion of the meet.

B. Starter

1. The duties of the Starter will include the following:
 - a. Provide a complete set of flags for use during the race, excluding yellow and ambulance flags.
 - b. Assign extra Flag men, when required, at various points throughout the course.
 - c. Determine if scorers, timers, umpires, etc., are ready and in place before starting the race.
 - d. Position riders at the starting line, start the race, give halfway flags, last lap flags and finish flags.
 - e. Flag off the course any disqualified riders and otherwise direct the progress of the race with flags, as instructed by the Referee.
 - f. Instruct the corner workers as to the performance of their duties, and insure that the promoter has supplied each flag man with a yellow caution flag and a white-with-red-cross (ambulance) flag.
 - g. Such other duties as may be assigned by the Referee.

C. Clerk of Course

1. The duties of the Clerk of Course will include the following:
 - a. Exhibit a list of all events.
 - b. Receive all entries and check the riders' AMA membership.

- c. Check riders' classification and place riders in proper events. Provide copies of the event lists for the Head Scorer and Pit Steward.
- d. Compile results of each event and be sure that the Pit Steward has two copies of the results for posting and lineup in the pits as soon as possible after each event. At the end of the meet insure that the final results are posted.
- e. Provide all lineup lists and result lists to the promoter for distribution to the press.
- f. Such other duties as may be assigned by the Referee.

D. Head Scorer

1. The duties of the Head Scorer will include the following:
 - a. See that a suitable checking stand is provided and at the proper place on the course.
 - b. See that the promoter or others have provided all of the necessary equipment for proper checking.
 - c. Provide, or see that the promoter has provided a sufficient number of Scorers.
 - d. Advise the Starter when the Scorers are ready and keep the Starter informed on finish information of each rider.
 - e. Complete and keep all scores and turn the same over to the Clerk of Course.

E. Timer

The Timer should provide electric timing equipment and will keep an accurate record of all times and report the same to the Clerk of Course when meeting requires timing.

F. Pit Steward and Assistant Pit Steward

1. The duties of the Pit Steward and Assistant will be as follows:
 - a. Notify riders to appear at the starting point in time for each event in which they are entered and assign proper starting positions.
 - b. Maintain neat, suitable and orderly pits for the riders to work from.

G. All Officials must be AMA members.